

# RGB Strobe Moving Head Light (Waterproof)



## User Manual

Note: This manual include important information on how to install and use it safely. Please read it carefully before install and operate as required. At the same time, please keep this manual properly for emergencies.

# 1 SAFETY INSTRUCTIONS

WARNING: READ THE SAFETY PRECAUTIONS IN THIS SECTION BEFORE INSTALLING, POWERING, OPERATING OR SERVING THIS PRODUCT.

warn! Shaking head strobe product according to the risk level of EN 62471. Do not view the light output with optical instruments or any equipment that may concentrate the beam.



This light fixture is for professional use only - not for home use. Fixtures must be installed by a qualified technician. Installation safety is the responsibility of the installer. There is a risk of serious injury or risk to the light fixture due to fire, electric shock and falling. This luminaire produces a powerful, concentrated light that can create a fire hazard or cause eye injury if the following safety precautions are not followed.

When installing, operating or servicing lamps, please comply with all applicable local laws, rules and regulations

Electric shock protection

1. Before performing any installation or maintenance work, disconnect from AC power when the fixture is not in use.

2. Make sure the light fixture is electrically connected to ground (ground).

3. Connect AC power to the luminaire only at 100 - 240 VAC, 50/60 Hz.

4. Use only AC power that complies with local building and electrical codes, with overload and ground fault (ground fault) protection.

5. Before using the luminaire, check that all power distribution equipment and cables are in good condition and evaluate the current requirements of all connected equipment.

6. If the power cord, power plug or any seals, housing or other parts are damaged, damaged, deformed, wet or showing signs of overheating, immediately disconnect the power source. Do not reuse the power supply until repairs are complete, and replace any defective parts with new ones.

7. Cables used to connect the product to AC power must be a minimum wire size of 14 AWG or 1.5 mm<sup>2</sup> and have a minimum heat resistance of 90°C (194°F). It must have three conductors with an outer cable diameter of 5 - 15 mm (0.2 - 0.6 in). In the U.S. and Canada, cables must be UL/CSA certified, using strict, type SJT or equivalent. In the EU, the cable must be type H05VV-F or equivalent.

8. Only connect cables with Neutrik PowerCON TRUE1 NAC3FX-W female connectors to the light's power input socket.

Prevent burns and fires

9. Do not operate the light fixture if the ambient temperature ( $T_a$ ) exceeds 40°C (104°F).

10. The exterior of the luminaire becomes hot during use. After 5 minutes of operation, the expected surface temperature is 70°C (158°F) and the maximum steady state is 80°C (176°F). Avoid contact with people and materials. Allow the fixture to cool for at least 10 minutes before handling.

11. Keep all combustible materials (eg: cloth, wood, paper) at least 20 cm (8



inches) away from light fixtures.

12. Keep flammable materials (eg volatile liquids, pyrotechnics, fuels of any type) away from fixtures.
13. Make sure there is unobstructed airflow around the fixture.
14. Do not illuminate surfaces within 1 meter (3 feet 4 inches) of the shaking head strobe.
15. Do not expose the front glass to sunlight or other strong light from any angle. The lens can focus the sun's rays inside the luminaire, creating a potential fire hazard.
16. Do not attempt to bypass thermostat switches or fuses.
17. Do not attach filters, masks or other materials to any lenses or other optical components.

prevent eye injury

18. Do not view the LEDs with magnifying glasses, telescopes, binoculars or similar optical instruments in order to concentrate the light output.
19. Do not operate the luminaire with missing or damaged covers, shields or any optics.
20. To reduce the risk of eye irritation or injury, do not always disconnect the light fixture when not in use, and provide well-lit conditions to reduce the pupil diameter of those working on or near the light fixture.

protect from harm

21. When in use, securely fasten the luminaire to a fixed surface or rigging structure. The luminaire cannot be moved during installation.
22. Block the work area under the work area and work from a stable platform when installing, servicing or moving light fixtures.
23. Ensure that all fasteners used to install the clamps are grade 8.8 minimum. Use unworn self-locking nuts on bolts and machine screws.
24. When hanging light fixtures, make sure that the support structure and all hardware used can withstand at least 10 times the weight of the equipment being supported.
25. In all truss mounted installations where the clamps are not suspended vertically in "free hanging mode", use rigging clamps that completely surround the truss chords and use grade 8.8 strength bolts to screw the clamps directly to the clamp's mounting brackets, since lock nut. Do not use any type of clamp that does not completely surround the truss chords, nor do you use omega brackets or any other intermediate rigging hardware.
26. If installing the luminaire in a location that could cause injury or a fall, secure the safety cable to the fixed anchor points and to the safety cable anchorage points on the fixture and noted in this manual so that the safety cable is at the main connection Grab the fixture when it fails. Do not use other parts of the luminaire as safety cable connection points.
27. Check that all exterior covers and rigging hardware are securely fastened.



First time use:

warn! Read "Safety Information" before installing, supplying power, operating or servicing

important! A moving head strobe is a solid fixture, but it must be protected from the environment

Factors such as physical shock and vibration during transportation and storage.

Before powering up,

28. Read the "Safety Information" carefully

29. Check that the local AC power source is within the power supply voltage and frequency range of the luminaire.

30. Check that the power input cable is "shock proof" alternating current



warn! Please read the Safety Information before connecting the strobe to AC power.

warn! To prevent electric shock, the shaking head strobe must be grounded (grounded). This distribution circuit must be equipped with fuses or circuit breakers and ground fault (earth fault) protection.

warn! The socket or external power switch is used to power the moving head strobe and must be located near the light fixture so that the light fixture can be easily disconnected from the power source.

important! Therefore, do not use an external dimming system to power the moving head strobe, it may cause damage to the light fixture not covered by the product warranty.

voltage

warn! Check the voltage range specified on the luminaire serial number label Match the local AC mains voltage before energizing the luminaire.

The moving head strobe has an auto-regulated power supply that accepts a nominal mains power supply of 100-240 VAC, 50/60Hz. Do not apply AC power of any other voltage or frequency to the fixture. During normal use, shaking head strobes can generate significant peak currents. To avoid overloading, allow a 16 or 20 amp branch circuit per fixture to run at full power. Two lamps may be placed on a 16 amp branch circuit, but the type of MCB (miniature circuit breaker) must also be considered: 16 Type C meets most needs (IEC 60898 / UL489 / CSA C22.2 No. 5).





physical installation

warn! Read "Safety Information" before installing, supplying power, operating or servicing

warn! Check that all surfaces to be illuminated are at least 1 m (3 ft 4 in) away from light fixtures. Combustible materials (wood, fabric, paper, etc.) are at least 20 cm (8 in.) away from light fixtures. There is free airflow around fixtures and no flammable items nearby.

warn! Do not expose the front glass to sunlight or other strong light.

If light from the sun or other fixtures hits the front glass directly or at an angle, a Fire hazard and damage to the interior of the luminaire or the edge of the front glass. Strong sunlight can

Damage in seconds! Cover the front glass before the fixture is exposed to sunlight or strong light

Or point the light fixture in the opposite direction of the light source.

Tilt adjustment

The moving head strobe mounting bracket can adjust and lock the tilt angle of the light fixture. To adjust tilt:

- Loosen the two tilt adjustment wheels until the teeth are tilted

The adjustment locking mechanism disengages and you are free to tilt the light fixture. If you can feel resistance, you may not be loosening the wheel enough when you try to tilt the clamp, and you may damage the teeth in the adjustment mechanism.

- Adjust the aiming, then retighten both wheels by hand. Tighten but do not use a tool to tighten, or damage may occur. The first few times you adjust the tilt, small particles of paint or metal rubbing may become visible. This is not a malfunction and will not cause any problems.

Fix the light fixture on a flat surface

The shaking head strobe can be fixed on the stage or other flat surface.

warn! The support surface must be hard and flat, otherwise the ventilation holes in the base may become blocked, which can lead to overheating. Secure the light fixture securely. Do not place it on a surface or where it may move or tip over.



Fix the shaking head strobe on a flat surface

- Check that the surface can withstand at least 10 times the weight of all fixtures and equipment mounted on it.
- Use at least one grade 8.8 M12 bolt to fasten the fixture's mounting bracket to the surface.
- If the main attachment fails, it may fall and cause injury or damage, please attach an approved attachment.

Mount the clamp on the truss

The shaking head strobe can be clamped to a truss or similar rigging structure in any direction. When mounted on a truss:

31. Check that the rigging structure can support at least 10 times the weight of all fixtures and equipment installed on it.
32. Check that all rigging hardware is intact and determined by weight.
33. Block access under the work area.
34. Work from a stable platform.
35. Use approved safety cables to prevent spreader hardware failure.

Depending on the orientation of the clamps, you can install the clamps on the truss using one of the following methods.

Truss mounted in any orientation

Fixtures to hang from rigging structures such as trusses in any orientation:

1. Attach a half-coupler rigging clamp that completely surrounds the truss chord directly to the truss's mounting bracket of the clamp with M12 grade 8.8 bolts through the holes in the mounting bracket and secure with unworn self-locking nuts. Do not use omega brackets.
2. Block access under the work area. From a stable job hang the spreader on the truss and fasten the half coupler clamps on the truss chord.
3. If the primary accessory fails and could fall and cause injury or damage, please attach an approved accessory safety cable to the safety anchor and one of the safety cable attachment points on the fixture
4. If necessary, adjust the orientation of the clamp by loosening the tilt adjustment wheel, adjust the target of the clamp and retighten the tilt adjustment wheel. Apply strong pressure by hand only - do not use tools to

tighten the tilt adjustment wheel. Truss Mounted Vertical Hanging in "Free Hanging Mode"

It is possible to install a vertically suspended shaking head strobe, down from the truss, and then set it to the desired inclination

Use the tilt adjustment wheel in the mounting bracket. To hang the spreader on a rigging structure such as a truss, it can only be hung vertically in "Free Hanging" mode.

## **2** ***LAMP APPEARANCE***

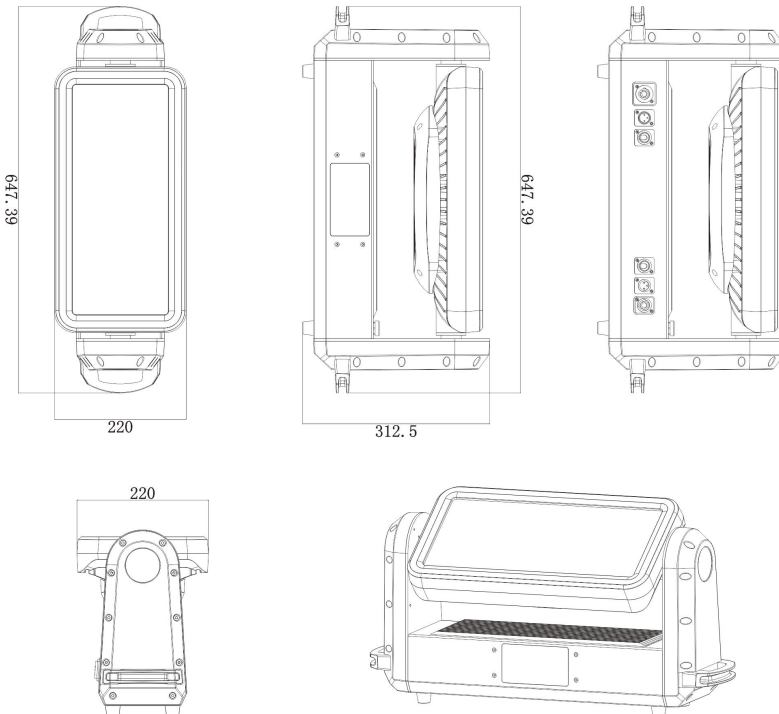

**3****FUNCTION SETTING**

Menu	Value	
DMX Address Set	1-512	DMX setting
Work Mode set	Slow	Slow mode
	Fast	Fast mode
	Input	Signal Input mode
Input mode set		6Ch mode
		20Ch mode
		41Ch mode
		444Ch mode
		DMX Net Mode
		All net mode
Invert TILT	Yes	Motor reverse control
	No	motor control normally
MOTOR FBACK	Yes	Sensor error
	No	Sensor error
Display Set	Yes	Backlight delay off
	NO	Backlight on
Net Mode Set	IP Address Set	IP setting
	Netmask Set	Netmask set
	Gateway Set	Gateway set
	MAC Address	MAC add
Restore Factory Setting	Yes	reset
Reset		Reset

## **4 Background processing**

**(Long press the menu key at A001)**

MOTOR Calibration	0-255	Motor zero adjustment
White Balance Set	SET_R	Red Led pixel brightness adjustment
	SET_G	Green Led pixel brightness adjustment
	SET_B	Blue Led pixel brightness adjustment
	SET_W	Strobe brightness adjustment
Motor Ampere Set	0-255	Motor current regulation
NTC ADC LEVE Show	0-4096	Display temperature detection constants
RGB Output Drive Set	MBI5042XX	Lamp bead driver selection MBI5042XX
	WS2812	Lamp bead driver selection WS2812
GB IMAGEA Set	YES	Module mirroring processing GB swap
	NO	Light board mirroring off

# **5** *DMX CHANNEL*

## **6channel**

6channel	DMX value	Function Description
Ch1		Pan control
	0-255	Pan rotation
Ch2		reset
	2-25	No function
	80-84	All reset
Ch3		Strobe dimming
	0-255	linear dimmer 0%-100%
Ch4	0-255	Red dim,linear dimmer 0%-100%
Ch5	0-255	Green dim,linear dimmer 0%-100%
Ch6	0-255	Blue dim,linear dimmer 0%-100%

# 20channel

20channel	DMX value	Function Description
Ch1	0-255	Pan rotation
Ch2	0-255	Pan fine 16 bit
Ch3	0-255	Pan Speed, fast-slow
Ch4	0-25	No Function
	80-84	All Reset
Ch5	0-255	Total dimmer (0-100%)
Ch6	0-24	Strobe on
	25-255	Strobe effect ,from slow to fast
Ch7	0-4	No effect
	5-255	select symbol,3 values one character
Ch8	0-4	No effect
	5-255	select symbol,3 values one character
Ch9	0-4	No effect
	5-255	Select color,4 values one color
Ch10	0-4	No effect
	5-255	Select color,4 values one color
Ch11	0-127	Normal
	128-255	Reverse
Ch12	0-4	No effect
	5-255	Select 3 values for each effect
Ch13	0-255	Auto effect, from slow to fast
Ch14	0-255	Led pixel,red color full control
Ch15	0-255	Led pixel,green color full control
Ch16	0-255	Led pixel,blue color full control
Ch17	0-255	Strobe, dimmer 0-100%
Ch18	0-24	Strobe open
	25-255	Strobe, from slow to fast
Ch19	0-5	No effect
	5-255	Strobe,from slow to fast

Ch20	0-255	Auto,from slow to fast
------	-------	------------------------

## 41channel (8 Segment)

41channel	DMX value	Function Description
Ch1	0-255	Pan rotation
Ch2	0-255	Pan fine 16 bit
Ch3	0-255	Pan speed, fast to slow
Ch4	0-25	No function
	80-84	Fill Reset
Ch5	0-255	Total dimmer (0-100%)
Ch6		LED RGB Strobe( Flash strobe not included)
	0-24	Strobe open
	25-255	Strobe, from slow to fast
Ch7	0-4	No effect
	5-255	select symbol,3 values one character
Ch8	0-4	No effect
	5-255	Select color,4 values one color
Ch9	0-4	No effect
	5-255	Select color,4 values one color
Ch10	0-4	No effect
	5-255	Select color,4 values one color
Ch11	0-127	Normal
	128-255	Reverse
Ch12	0-4	No effect
	5-255	select symbol,3 values one effect
Ch13	0-255	Auto speed, from slow to fast
Ch14	0-255	Flash Strobe dimming, dimmer 0-100%
Ch15	0-24	Flash Strobe open
	25-255	Flash Strobe,from slow to fast
Ch16	0-5	No effect
	5-255	Flash Strobe,from slow to fast
Ch17-40	0-255	Auto Flash Strobe,from slow to fast
Ch18-41	0-255	Led pixel control, red color segment control
	0-255	Led pixel control, green color segment control

0-255	Led pixel control, blue color segment control
-------	---

# 444channel (144 Segment)

444channel	DMX value	Function Description
Ch1	0-255	Pan rotation
Ch2	0-255	Pan fine 16 bit
Ch3	0-255	Pan speed, fast-slow
Ch4	0-25	No function
	80-84	Full Reset
Ch5-12		Single flash Strobe, total 8
	0-255	Liner dimmer 0-100%
Ch13-444	0-255	Led pixel control, red color 144 segment control
	0-255	Led pixel control, green color 144 segment control
	0-255	Led pixel control, blue color 144 segment control

## DMX NET

DMX NET	DMX Value	Pixel control using network, motor and flash using DMX
<b>0-2952 Channel</b>		<b>Channel mapping: Mapping table of network port pixel-controlled channels</b>
<b>Total device: 2953 DMX Channel: 1</b>	<b>0-255</b>	<b>Pan rotation</b>
<b>Total device: 2954 DMX Channel: 2</b>	<b>0-255</b>	<b>Pan fine, 16 bit</b>
<b>Total device: 2955 DMX Channel: 3</b>	<b>0-255</b>	<b>Pan speed, fast to slow</b>
<b>Total device: 2956 DMX Channel: 4</b>	<b>0-25</b>	<b>No effect</b>
	<b>80-84</b>	<b>Full reset</b>
<b>Total device: 2957-2964</b>		<b>Single flash strobe, total 8</b>
	<b>0-255</b>	<b>Linear dimming 0-100%</b>

## ALL NET

All NET	DMX Value	Network mode: All network control
0-2952 Channel		Channel mapping: Mapping table of network port pixel-controlled channels
Total device: 2953 DMX Channel: F43	0-255	Pan rotation
Total device: 2954 DMX Channel: F44	0-255	Pan fine, 16 bit
Total device: 2955 DMX Channel: F45	0-255	Pan speed, fast to slow
Total device: 2956 DMX Channel: F46	0-25	No effect
	80-84	Full reset
Total device: 2957-2964		Single flash strobe, total 8
	0-255	Linear dimming 0-100%

# 6 LED Pixel Position Map

1 position corresponds to 3 RGB channels, 6 DMX lines A-F

	1	2	3	4	5	6	7	8	9	10	11	12	13	14	15	16	17	18
1	A001	A004	A007	A010	A013	A016	A019	A022	A025	A028	A031	A034	A037	A040	A043	A046	A049	A052
2	A163	A166	A169	A172	A175	A178	A181	A184	A187	A190	A193	A196	A199	A202	A205	A208	A211	A214
3	A325	A328	A331	A334	A337	A340	A343	A346	A349	A352	A355	A358	A361	A364	A367	A370	A373	A376
4	A487	A490	A493	A496	A499	A502	A505	A508	B001	B004	B007	B010	B013	B016	B019	B022	B025	B028
5	B139	B142	B145	B148	B151	B154	B157	B160	B163	B166	B169	B172	B175	B178	B181	B184	B187	B190
6	B301	B304	B307	B310	B313	B316	B319	B322	B325	B328	B331	B334	B337	B340	B343	B346	B349	B352
7	B463	B466	B469	B472	B475	B478	B481	B484	B487	B490	B493	B496	B499	B502	B505	B508	C001	C004
8	C115	C118	C121	C124	C127	C130	C133	C136	C139	C142	C145	C148	C151	C154	C157	C160	C163	C166
9	C277	C280	C283	C286	C289	C292	C295	C298	C301	C304	C307	C310	C313	C316	C319	C322	C325	C328
10	C439	C442	C445	C448	C451	C454	C457	C460	C463	C466	C469	C472	C475	C478	C481	C484	C487	C490
11	D091	D094	D097	D100	D103	D106	D109	D112	D115	D118	D121	D124	D127	D130	D133	D136	D139	D142
12	D253	D256	D259	D262	D265	D268	D271	D274	D277	D280	D283	D286	D289	D292	D295	D298	D301	D304
13	D415	D418	D421	D424	D427	D430	D433	D436	D439	D442	D445	D448	D451	D454	D457	D460	D463	D466
14	E067	E070	E073	E076	E079	E082	E085	E088	E091	E094	E097	E100	E103	E106	E109	E112	E115	E118
15	E229	E232	E235	E238	E241	E244	E247	E250	E253	E256	E259	E262	E265	E268	E271	E274	E277	E280
16	E391	E394	E397	E400	E403	E406	E409	E412	E415	E418	E421	E424	E427	E430	E433	E436	E439	E442

	19	20	21	22	23	24	25	26	27	28	29	30	31	32	33	34	35	36
1	A055	A058	A061	A064	A067	A070	A073	A076	A079	A082	A085	A088	A091	A094	A097	A100	A103	A106
2	A217	A220	A223	A226	A229	A232	A235	A238	A241	A244	A247	A250	A253	A256	A259	A262	A265	A268
3	A379	A382	A385	A388	A391	A394	A397	A400	A403	A406	A409	A412	A415	A418	A421	A424	A427	A430
4	B031	B034	B037	B040	B043	B046	B049	B052	B055	B058	B061	B064	B067	B070	B073	B076	B079	B082
5	B193	B196	B199	B202	B205	B208	B211	B214	B217	B220	B223	B226	B229	B232	B235	B238	B241	B244
6	B355	B358	B361	B364	B367	B370	B373	B376	B379	B382	B385	B388	B391	B394	B397	B400	B403	B406
7	C007	C010	C013	C016	C019	C022	C025	C028	C031	C034	C037	C040	C043	C046	C049	C052	C055	C058
8	C169	C172	C175	C178	C181	C184	C187	C190	C193	C196	C199	C202	C205	C208	C211	C214	C217	C220
9	C331	C334	C337	C340	C343	C346	C349	C352	C355	C358	C361	C364	C367	C370	C373	C376	C379	C382
10	C493	C496	C499	C502	C505	C508	D001	D004	D007	D010	D013	D016	D019	D022	D025	D028	D031	D034
11	D145	D148	D151	D154	D157	D160	D163	D166	D169	D172	D175	D178	D181	D184	D187	D190	D193	D196
12	D307	D310	D313	D316	D319	D322	D325	D328	D331	D334	D337	D340	D343	D346	D349	D352	D355	D358
13	D469	D472	D475	D478	D481	D484	D487	D490	D493	D496	D499	D502	D505	D508	E001	E004	E007	E010
14	E121	E124	E127	E130	E133	E136	E139	E142	E145	E148	E151	E154	E157	E160	E163	E166	E169	E172
15	E283	E286	E289	E292	E295	E298	E301	E304	E307	E310	E313	E316	E319	E322	E325	E328	E331	E334
16	E445	E448	E451	E454	E457	E460	E463	E466	E469	E472	E475	E478	E481	E484	E487	E490	E493	E496

	37	38	39	40	41	42	43	44	45	46	47	48	49	50	51	52	53	54
1	A109	A112	A115	A118	A121	A124	A127	A130	A133	A136	A139	A142	A145	A148	A151	A154	A157	A160
2	A271	A274	A277	A280	A283	A286	A289	A292	A295	A298	A301	A304	A307	A310	A313	A316	A319	A322
3	A433	A436	A439	A442	A445	A448	A451	A454	A457	A460	A463	A466	A469	A472	A475	A478	A481	A484
4	B085	B088	B091	B094	B097	B100	B103	B106	B109	B112	B115	B118	B121	B124	B127	B130	B133	B136
5	B247	B250	B253	B256	B259	B262	B265	B268	B271	B274	B277	B280	B283	B286	B289	B292	B295	B298
6	B409	B412	B415	B418	B421	B424	B427	B430	B433	B436	B439	B442	B445	B448	B451	B454	B457	B460
7	C061	C064	C067	C070	C073	C076	C079	C082	C085	C088	C091	C094	C097	C100	C103	C106	C109	C112
8	C223	C226	C229	C232	C235	C238	C241	C244	C247	C250	C253	C256	C259	C262	C265	C268	C271	C274
9	C385	C388	C391	C394	C397	C400	C403	C406	C409	C412	C415	C418	C421	C424	C427	C430	C433	C436
10	D037	D040	D043	D046	D049	D052	D055	D058	D061	D064	D067	D070	D073	D076	D079	D082	D085	D088
11	D199	D202	D205	D208	D211	D214	D217	D220	D223	D226	D229	D232	D235	D238	D241	D244	D247	D250
12	D361	D364	D367	D370	D373	D376	D379	D382	D385	D388	D391	D394	D397	D400	D403	D406	D409	D412
13	E013	E016	E019	E022	E025	E028	E031	E034	E037	E040	E043	E046	E049	E052	E055	E058	E061	E064
14	E175	E178	E181	E184	E187	E190	E193	E196	E199	E202	E205	E208	E211	E214	E217	E220	E223	E226
15	E337	E340	E343	E346	E349	E352	E355	E358	E361	E364	E367	E370	E373	E376	E379	E382	E385	E388
16	E499	E502	E505	E508	F001	F004	F007	F010	F013	F016	F019	F022	F025	F028	F031	F034	F037	F040

# **7** ***TECHNICAL PARAMETER***

Power: AC100-240V50/60Hz3000W

Light Source : 864pcs 0.5W RGB LEDs &160pcs 10W white LEDs, 8 segments white LED controlled independently no ultraviolet radiation864 segments RGB

Life Time : Over 20,000 hours for the LED light source

Output : 70,000 lm

Beam Angle: 120 degrees

Tilt angle: 190 degrees

Control mode: DMX512, self-go, main-slave, Art-Net, with RDM function

DMX Mode : 6/20/41/444/DMX channels

Dimmer: 32 bit dimmer

Operating Mode DMX Mode/Master-Slave mode/Pixel mode

Over Heat Protect With temperature sensor to extend the lamp's life

LED Scan Rate 9,000 Hz LED scan rate

Waterproof Rating : IP65

Weight: 18KG

## **Effect:**

1. Beam is a high-intensity array that provides powerful stroboscopic and masking effects

## **Strobe effect**

Moving head strobe provides variable flash frequency, flash duration and strobe effect intensity of the beam. It also provides the following pre-programmed effects:

2. Raise/lower the intensity modulation effect
3. Random Blinks
4. Spikes - low intensity light output of high intensity flashes.

## **masking effect**

For a continuous shading effect, set the flash duration to a longer value and the flash frequency to a higher frequency

The value flashes "overlap" and merge into a continuous light output.

## Service and Repair:



warn! Disconnect light fixture from AC power and allow to cool for at least 10 minutes before handling. If connected to power, be prepared for a sudden lighting of the light fixture.



warn! Refer any service operations to a qualified service technician.  
important! Excessive dust, smoke and accumulated particles can reduce performance, cause overheating and damage the light fixture. Damage due to improper cleaning or maintenance is not covered by the product warranty.

The user needs to clean up the shaking head strobe regularly, and the user can also update the software of the lamp.

LEDs are subject to wear and tear over the life of the product, resulting in gradual changes in color and overall brightness over thousands of hours of use. The degree of wear and tear is highly dependent on operating conditions and environment, so it is impossible to specify precisely whether and to what extent LED performance is affected. However, after prolonged use, if its characteristics are affected by wear and tear, and the fixture needs to perform with very precise optical and color parameters, you may eventually need to replace the LED. Manufacturer's LED lifetime data is based on performance under manufacturer's test conditions. As compared to all LEDs, the gradual decrease in luminous output will be accelerated when LEDs are used in fixtures, and the conditions in this case are much more difficult than the manufacturer's test. To maximize the life of the LEDs, keep the ambient temperature as low as possible and drive the LEDs as little as possible and not for too long.

## Cleaning:

warn! Disconnect power and allow to cool before cleaning.

Cleaning schedules for lighting fixtures vary widely depending on the operating environment. It is therefore not possible to specify an exact cleaning interval for the shaking head strobe.

Environmental factors that can cause frequent cleanings include:

5. Use a fog machine.
6. High air velocities (eg near air conditioning vents).
7. Presence of cigarette smoke.
8. Airborne dust (eg stage effects, building structures and fittings or the natural environment of outdoor events).

If one or more of these factors are present, inspect the light fixture within the first 100 hours of operation to see if it needs cleaning. Check again frequently. This program will allow you to assess your cleaning requirements in a specific situation.

Use gentle pressure only when cleaning and work in a clean, well-lit area. Do not use products containing solvents or abrasives, which may cause surface damage.